



THE



THA



TFF



TFE



THT



TFM



TFN



THP



TFS

CARACTÉRISTIQUES

- Un avant-trou est nécessaire; le filetage du matériau de support s'effectue durant l'installation de l'ancrage.
- Utilisable pour des charges hautes.
- Apte pour 2 profondeurs d'installation et même 3 avec le Ø10.
- Fixations structurelles dans le béton fissuré et non fissuré en intérieurs et extérieurs
- Conçu pour le béton fissuré et non fissuré.
- Utiliser pour les charges statiques ou quasi-statiques.
- Installation facile.
- Installation directe à travers le trou de la plaque d'ancrage.
- Peut se démonter, en laissant la superficie diaphane.
- Variété de longueurs et métriques, flexibilité dans l'assemblage.
- Disponible en INDEXcal

APPLICATION

- Fixations structurelles en béton fissure et non fissuré
- Vitrages, fenêtres et vitrines.
- Étagères et racks
- Installation de balustrades et rampes en intérieurs
- Fixation de structures en bois dans béton

EVALUATION



MATÉRIAU BASE



GAMME DE MESURES

Ø5 - Ø18

CONDITIONNEMENT DU TROU



SEC



HUMIDE







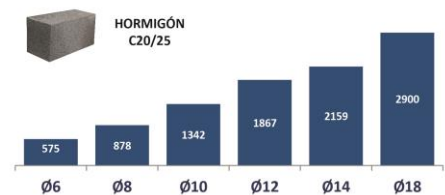



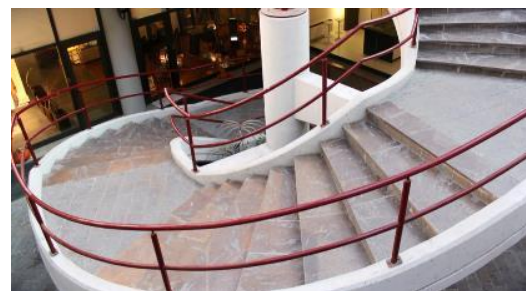

INONDÉ

CHARGES MAXIMALES RECOMMANDÉES À LA TRACTION DANS LE BÉTON FISSURÉ ET NON FISSURÉ [kg]



EXEMPLES D'APPLICATION

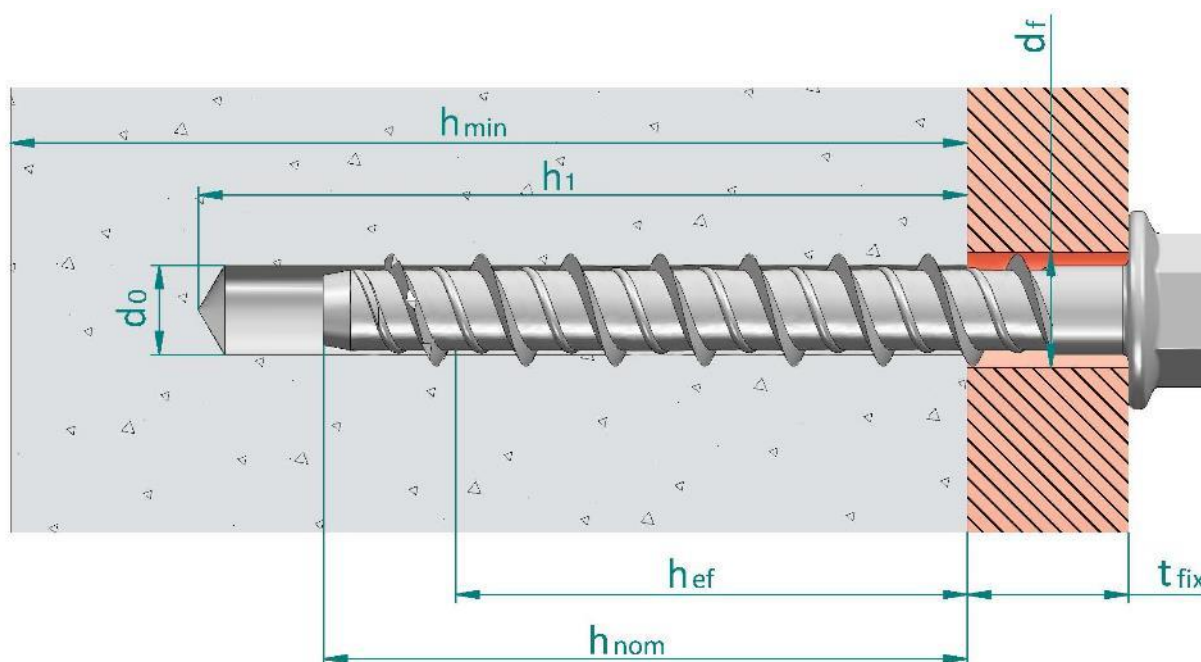

1. GAMME					
ITEM	CODE	SIZES	PHOTO	DESCRIPTION	MATÉRIAU
1	THE	Ø5 - Ø18		Tête hexagonale à collerette	Acier au carbone estampé , ATLANTIS revêtement
2	TFE	Ø5 - Ø18		Tête hexagonale à collerette	Acier au carbone estampé, zingué ≥ 5 µm
3	TFN	Ø14		Tête hexagonale	Acier au carbone estampé, zingué ≥ 5 µm
4	THA	Ø5 - Ø10		Fraisée, creux hexalobulaire	Acier au carbone estampé , ATLANTIS revêtement
5	THT	Ø6		Tête bombée, empreinte hexalobulaire	Acier au carbone estampé , ATLANTIS revêtement
6	THP	Ø5 - Ø8		Tête ronde, empreinte hexalobulaire	Acier au carbone estampé , ATLANTIS revêtement
7	TFF	Ø6		Filetage femelle (fixation de tiges)	Acier au carbone estampé, zingué ≥ 5 µm
8	TFM	Ø6		Filetage mâle	Acier au carbone estampé, zingué ≥ 5 µm
9	TFS	Ø6 - Ø10		Tête filetée	Acier au carbone estampé, zingué ≥ 5 µm

2. DONNÉES D'INSTALLATION**2.1. PLAN D'INSTALLATION**

- d_0 : Diamètre du foret
 d_f : Diamètre du trou d'épassieur à fixer
 h_{ef} : Profondeur effective
 h_1 : Profondeur du trou foré
 h_{nom} : Profondeur d'installation
 h_{min} : Épaisseur minimale du béton
 t_{fix} : Épaisseur à fixer

3. PARAMETRES D'INSTALLATION

Paramètres généraux d'installation

Profondeur d'installation standard

Profondeur d'installation réduite

Familie	Code	Dimension	Evaluation	Diamètre du foret	Diamètre du trou d'épaisseur à fixer	Version du tête	Couple de serrage maximal	Distance minimale entre axes	Distance minimale au bord	Épaisseur minimale du béton	Profondeur du trou foré	Profondeur d'installation	Profondeur effective	Épaisseur à fixer	Distance minimale entre axes (cône)	Distance critique au bord (cône)	Distance minimale entre axes (fissuration)	Distance critique au bord (fissuration)	Épaisseur minimale du béton	Profondeur du trou foré	Profondeur d'installation	Profondeur effective	Épaisseur à fixer	Distance minimale entre axes (cône)	Distance critique au bord (cône)	Distance minimale entre axes (fissuration)	Distance critique au bord (fissuration)
THE	THE05040	Ø5 x 40	--	5	7	SW 8	8	35	35	--	--	--	--	--	--	--	--	--	100	40	35	25,0	5	75	38	90	45
	THE05050	Ø5 x 50	--			15																					
	THE05060	Ø5 x 60	--			25																					
	THE05080	Ø5 x 80	--			45																					
	THE05100	Ø5 x 100	--			65																					
	THE06040	Ø6 x 40	✓	6	9	SW 10	10	35	35	--	--	--	--	--	--	--	--	--	100	45	35	26,0	5	78	39	90	45
	THE06050	Ø6 x 50	✓			15																					
	THE06060	Ø6 x 60	✓			25																					
	THE06070	Ø6 x 70	✓			35																					
	THE06080	Ø6 x 80	✓			45																					
	THE06100	Ø6 x 100	✓	65																							
	THE06120	Ø6 x 120	✓	85																							
	THE08055	Ø8 x 55	✓	8	12	SW 13	20	35	35	--	--	--	--	--	--	--	--	--	100	60	50	37,5	5	113	57	130	65
	THE08060	Ø8 x 60	✓			10																					
	THE08070	Ø8 x 70	✓			20																					
	THE08080	Ø8 x 80	✓			15																					
	THE08090	Ø8 x 90	✓			25																					
	THE08100	Ø8 x 100	✓			35																					
	THE08110	Ø8 x 110	✓			45																					
	THE08120	Ø8 x 120	✓			55																					
	THE08140	Ø8 x 140	✓			75																					
	THE10060	Ø10 x 60	✓	10	14	SW 15	30	50	40	--	--	--	--	--	--	--	--	--	100	65	55	41,5	5	125	63	140	70
	THE10070	Ø10 x 70	✓			15																					
	THE10080	Ø10 x 80	✓			25																					
THE10090	Ø10 x 90	✓	35																								
THE10100	Ø10 x 100	✓	45																								
THE10120	Ø10 x 120	✓	65																								
THE10140	Ø10 x 140	✓	85																								

Paramètres généraux d'installation										Profondeur d'installation standard								Profondeur d'installation réduite									
Famille	Code	Dimension	Evaluation	Diamètre du foret	Diamètre du trou d'épaisseur à fixer	Version du tete	Couple de serrage maximal	Distance minimale entre axes	Distance minimale au bord	Épaisseur minimale du béton	Profondeur du trou foré	Profondeur d' installation	Profondeur effective	Épaisseur à fixer	Distance minimale entre axes (cône)	Distance critique au bord (cône)	Distance minimale entre axes (fissuration)	Distance critique au bord (fissuration)	Épaisseur minimale du béton	Profondeur du trou foré	Profondeur d' installation	Profondeur effective	Épaisseur à fixer	Distance minimale entre axes (cône)	Distance critique au bord (cône)	Distance minimale entre axes (fissuration)	Distance critique au bord (fissuration)
[--]	[--]	[--]	ETA	d ₀ [mm]	d _f [mm]	SW/Tx [--]	T _{inst} [Nm]	S _{min} [mm]	C _{min} [mm]	h _{min} [mm]	h ₁ [mm]	h _{nom} [mm]	h _{ef} [mm]	t _{fix} [mm]	S _{cr,N} [mm]	C _{cr,N} [mm]	S _{cr,sp} [mm]	C _{cr,sp} [mm]	h _{min} [mm]	h ₁ [mm]	h _{nom} [mm]	h _{ef} [mm]	t _{fix} [mm]	S _{cr,N} [mm]	C _{cr,N} [mm]	S _{cr,sp} [mm]	C _{cr,sp} [mm]
THE	THE12080	Ø12 x 80	✓	12	16	SW 18	50	75	45	--	--	--	--	--	--	--	--	--	120	90	75	58,0	5	174	87	190	95
	THE12090	Ø12 x 90	✓			SW 18				--	--	--	--	--	--	15											
	THE12110	Ø12 x 110	✓			SW 18				5	251	126	220	110	35												
	THE12130	Ø12 x 130	✓			SW 18				25					55												
	THE12150	Ø12 x 150	✓			SW 18				45					75												
	THE14080	Ø14 x 80	✓	14	18	SW 21	70	80	50	--	--	--	--	--	--	--	--	--	120	90	75	58,0	5	174	87	190	95
	THE14100	Ø14 x 100	✓			SW 21				--	--	--	--	--	25												
	THE14120	Ø14 x 120	✓			SW 21				5	276	138	230	115	45												
	THE14130	Ø14 x 130	✓			SW 21				15					55												
	THE14140	Ø14 x 140	✓			SW 21				25					65												
	THE14160	Ø14 x 160	✓			SW 21				45					85												
	THE18100	Ø18 x 100	✓	18	22	SW 24	90	90	55	--	--	--	--	--	--	--	--	--	140	110	90	69,5	10	209	105	230	115
	THE18130	Ø18 x 130	✓			SW 24				--	--	--	--	--	40												
	THE18160	Ø18 x 160	✓			SW 24				20	336	168	350	175	70												
	THE18180	Ø18 x 180	✓			SW 24				40					90												
THE18200	Ø18 x 200	✓	SW 24			60				110																	

Paramètres généraux d'installation										Profondeur d'installation standard								Profondeur d'installation réduite																															
Famille	Code	Dimension	Evaluation	Diamètre du foret	Diamètre du trou d'épaisseur à fixer	Version du tete	Couple de serrage maximal	Distance minimale entre axes	Distance minimale au bord	Épaisseur minimale du béton	Profondeur du trou foré	Profondeur d' installation	Profondeur effective	Épaisseur à fixer	Distance minimale entre axes (cône)	Distance critique au bord (cône)	Distance minimale entre axes	Distance critique au bord (fissuration)	Épaisseur minimale du béton	Profondeur du trou foré	Profondeur d' installation	Profondeur effective	Épaisseur à fixer	Distance minimale entre axes (cône)	Distance critique au bord (cône)	Distance minimale entre axes	Distance critique au bord (fissuration)																						
[--]	[--]	[--]	ETA	d ₀ [mm]	d _f [mm]	SW/Tx [--]	T _{inst} [Nm]	S _{min} [mm]	C _{min} [mm]	h _{min} [mm]	h ₁ [mm]	h _{nom} [mm]	h _{ef} [mm]	t _{fix} [mm]	S _{cr,N} [mm]	C _{cr,N} [mm]	S _{cr,sp} [mm]	C _{cr,sp} [mm]	h _{min} [mm]	h ₁ [mm]	h _{nom} [mm]	h _{ef} [mm]	t _{fix} [mm]	S _{cr,N} [mm]	C _{cr,N} [mm]	S _{cr,sp} [mm]	C _{cr,sp} [mm]																						
TFE	TFE05040	Ø5 x 40	--	5	7	SW 8	8	35	35	100	55	45	35,0	--	105	53	170	85	100	40	35	25,0	5	75	38	90	45																						
	TFE05050	Ø5 x 50	--			SW 8								15																																			
	TFE05060	Ø5 x 60	--			SW 8								35																																			
	TFE05080	Ø5 x 80	--			SW 8								55																																			
	TFE05100	Ø5 x 100	--			SW 8																																											
	TFE06040	Ø6 x 40	✓	6	9	SW 10	10	35	35	--	100	65	55	43,0	--	129	65	170	85	100	45	35	26,0	5	78	39	90	45																					
	TFE06050	Ø6 x 50	✓			SW 10				15																																							
	TFE06060	Ø6 x 60	✓			SW 10				25																																							
	TFE06070	Ø6 x 70	✓			SW 10				45																																							
	TFE06080	Ø6 x 80	✓			SW 10				65																																							
	TFE06100	Ø6 x 100	✓			SW 10																																											
	TFE06120	Ø6 x 120	✓			SW 10																																											
	TFE08055	Ø8 x 55	✓			8				12					SW 13									20					35	35	--	100	75	65	50,5	--	152	76	200	100	100	60	50	37,5	5	113	57	130	65
	TFE08060	Ø8 x 60	✓												SW 13																10																		
	TFE08070	Ø8 x 70	✓												SW 13																20																		
	TFE08080	Ø8 x 80	✓	SW 13	30																																												
	TFE08090	Ø8 x 90	✓	SW 13	40																																												
	TFE08100	Ø8 x 100	✓	SW 13	50																																												
	TFE08110	Ø8 x 110	✓	SW 13	60																																												
	TFE08120	Ø8 x 120	✓	SW 13	70																																												
	TFE08140	Ø8 x 140	✓	SW 13	90																																												
TFE10060	Ø10 x 60	✓	10	14	SW 15		30	50	40		--	135	95	85	67,0	--	201	101	210	105	100	65	55		41,5	5	125	63			140					70													
TFE10070	Ø10 x 70	✓			SW 15	15																																											
TFE10080	Ø10 x 80	✓			SW 15	25																																											
TFE10090	Ø10 x 90	✓			SW 15	35																																											
TFE10100	Ø10 x 100	✓			SW 15	45																																											
TFE10120	Ø10 x 120	✓			SW 15	65																																											
TFE10140	Ø10 x 140	✓			SW 15	85																																											

Paramètres généraux d'installation

Profondeur d'installation standard

Profondeur d'installation réduite

Famille	Code	Dimension	Evaluation	Diamètre du foret	Diamètre du trou d'épaisseur à fixer	Version du tete	Couple de serrage maximal	Distance minimale entre axes	Distance minimale au bord	Épaisseur minimale du béton	Profondeur du trou foré	Profondeur d' installation	Profondeur effective	Épaisseur à fixer	Distance minimale entre axes (cône)	Distance critique au bord (cône)	Distance minimale entre axes (fissuration)	Distance critique au bord (fissuration)	Épaisseur minimale du béton	Profondeur du trou foré	Profondeur d' installation	Profondeur effective	Épaisseur à fixer	Distance minimale entre axes (cône)	Distance critique au bord (cône)	Distance minimale entre axes (fissuration)	Distance critique au bord (fissuration)
				d ₀ [mm]	d _f [mm]	SW/Tx [--]	T _{inst} [Nm]	S _{min} [mm]	C _{min} [mm]	h _{min} [mm]	h ₁ [mm]	h _{nom} [mm]	h _{ef} [mm]	t _{fix} [mm]	S _{cr,N} [mm]	C _{cr,N} [mm]	S _{cr,sp} [mm]	C _{cr,sp} [mm]	h _{min} [mm]	h ₁ [mm]	h _{nom} [mm]	h _{ef} [mm]	t _{fix} [mm]	S _{cr,N} [mm]	C _{cr,N} [mm]	S _{cr,sp} [mm]	C _{cr,sp} [mm]
TFE	TFE12080	Ø12 x 80	✓	12	16	SW 18	50	75	45	--	--	--	--	--	--	--	--	--	120	90	75	58,0	5	174	87	190	95
	TFE12090	Ø12 x 90	✓			SW 18				--	--	--	--	--	15												
	TFE12110	Ø12 x 110	✓			SW 18				5	251	126	220	110	35												
	TFE12130	Ø12 x 130	✓			SW 18				25					55												
	TFE12150	Ø12 x 150	✓			SW 18				45					75												
	TFE14080	Ø14 x 80	✓	14	18	SW 21	70	80	50	--	--	--	--	--	--	--	--	--	120	90	75	58,0	5	174	87	190	95
	TFE14100	Ø14 x 100	✓			SW 21				--	--	--	--	25													
	TFE14120	Ø14 x 120	✓			SW 21				5	276	138	230	115	45												
	TFE14130	Ø14 x 130	✓			SW 21				15					55												
	TFE14140	Ø14 x 140	✓			SW 21				25					65												
	TFE14160	Ø14 x 160	✓			SW 21				45					85												
	TFE18100	Ø18 x 100	✓	18	22	SW 24	90	90	55	--	--	--	--	--	--	--	--	--	140	110	90	69,5	10	209	105	230	115
	TFE18130	Ø18 x 130	✓			SW 24				--	--	--	--	40													
	TFE18160	Ø18 x 160	✓			SW 24				20	336	168	350	175	70												
TFE18180	Ø18 x 180	✓	SW 24			40				90																	
TFE18200	Ø18 x 200	✓	SW 24			60				110																	
TFN	TFN14080	Ø14 x 80	✓			14				18					SW 24	70	80	50					--				

Paramètres généraux d'installation										Profondeur d'installation standard								Profondeur d'installation réduite																						
Famille	Code	Dimension	Evaluation	Diamètre du foret	Diamètre du trou d'épaisseur à fixer	Version du tete	Couple de serrage maximal	Distance minimale entre axes	Distance minimale au bord	Epaisseur minimale du béton	Profondeur du trou foré	Profondeur d' installation	Profondeur effective	Épaisseur à fixer	Distance minimale entre axes (cône)	Distance critique au bord (cône)	Distance minimale entre axes (fissuration)	Distance critique au bord (fissuration)	Epaisseur minimale du béton	Profondeur du trou foré	Profondeur d' installation	Profondeur effective	Épaisseur à fixer	Distance minimale entre axes (cône)	Distance critique au bord (cône)	Distance minimale entre axes (fissuration)	Distance critique au bord (fissuration)													
[-]	[-]	[-]	ETA	d ₀ [mm]	d _f [mm]	SW/Tx [-]	T _{inst} [Nm]	S _{min} [mm]	C _{min} [mm]	h _{min} [mm]	h ₁ [mm]	h _{nom} [mm]	h _{ef} [mm]	t _{fix} [mm]	S _{cr,N} [mm]	C _{cr,N} [mm]	S _{cr,sp} [mm]	C _{cr,sp} [mm]	h _{min} [mm]	h ₁ [mm]	h _{nom} [mm]	h _{ef} [mm]	t _{fix} [mm]	S _{cr,N} [mm]	C _{cr,N} [mm]	S _{cr,sp} [mm]	C _{cr,sp} [mm]													
THA	THA05040	Ø5 x 40	--	5	7	TX25	8	35	35	--	--	--	--	--	--	--	--	--	100	40	35	25,0	5	75	38	90	45													
	THA05060	Ø5 x 60	--			TX25				15	105	53	170	85	25																									
	THA05080	Ø5 x 80	--			TX25				35					45	35	45																							
	THA05100	Ø5 x 100	--			TX25				55					65																									
	THA06045	Ø6 x 45	✓	6	9	TX30	10	35	35	--	--	--	--	--	--	--	--	--	100	45	35	26,0	10	78	39	90	45													
	THA06050	Ø6 x 50	✓			TX30				15																														
	THA06060	Ø6 x 60	✓			TX30				5	129	65	170	85	25																									
	THA06080	Ø6 x 80	✓			TX30				25					65	85																								
	THA06120	Ø6 x 120	✓			TX30				65					85																									
	THA06140	Ø6 x 140	✓			TX30				85	105																													
	THA08060	Ø8 x 60	✓			8				12	TX45	20	35	35	--	--	--	--					--					--	--	--	--	100	60	50	37,5	10	113	57	130	65
	THA08080	Ø8 x 80	✓								TX45				15																									
	THA08100	Ø8 x 100	✓	TX45	35		152	76	200		100				50	37,5	50																							
	THA08120	Ø8 x 120	✓	TX45	55		70																																	
THA10100	Ø10 x 100	✓	10	14	TX50	30	50	40	135	95	85	67,0	15	201	101	210	105	100	65	55	41,5	45	125	63	140	70														
THA10120	Ø10 x 120	✓			TX50				35	65																														
THT	THT06040	Ø6 x 40	✓	6	9	TX30	10	35	35	--	--	--	--	--	--	--	--	--	100	45	35	26,0	5	78	39	90	45													
	THT06050	Ø6 x 50	✓			TX30				15																														
	THT06060	Ø6 x 60	✓			TX30				100	65	55	43,0	5	129	65	170	85																						
THP	THP05040	Ø5 x 40	--	5	7	TX30	8	35	35	--	--	--	--	--	--	--	--	--	100	40	35	25,0	5	75	38	90	45													
	THP05060	Ø5 x 60	--			TX30				100	50	45	35,0	15	105	53	170	85					25																	
	THP06040	Ø6 x 40	✓			TX40				--	--	--	--	--	--	--	--	--					5																	
	THP06050	Ø6 x 50	✓			TX40				--	--	--	--	--	--	--	--	--					15																	
	THP06060	Ø6 x 60	✓	6	9	TX40	10	35	35	100	65	55	43,0	5	129	65	170	85	100	45	35	26,0	25	78	39	90	45													
	THP06080	Ø6 x 80	✓			TX40				25																														
	THP06100	Ø6 x 100	✓			TX40				45																														
	THP06160	Ø6 x 160	✓			TX40				65																														
THP08060	Ø8 x 60	✓	8	12	TX45	20	35	35	--	--	--	--	--	--	--	--	--	100	60	50	37,5	10	113	57	130	65														
THP08080	Ø8 x 80	✓			TX45				15																															

Paramètres généraux d'installation										Profondeur d'installation standard								Profondeur d'installation réduite									
Famille	Code	Dimension	Evaluation	Diamètre du foret	Diamètre du trou d'épaisseur à fixer	Version du tete	Couple de serrage maximal	Distance minimale entre axes	Distance minimale au bord	Épaisseur minimale du béton	Profondeur du trou foré	Profondeur d' installation	Profondeur effective	Épaisseur à fixer	Distance minimale entre axes (cône)	Distance critique au bord (cône)	Distance minimale entre axes (fissuration)	Distance critique au bord (fissuration)	Épaisseur minimale du béton	Profondeur du trou foré	Profondeur d' installation	Profondeur effective	Épaisseur à fixer	Distance minimale entre axes (cône)	Distance critique au bord (cône)	Distance minimale entre axes (fissuration)	Distance critique au bord (fissuration)
[-]	[-]	[-]	ETA	d ₀ [mm]	d _f [mm]	SW/Tx [-]	T _{inst} [Nm]	S _{min} [mm]	C _{min} [mm]	h _{min} [mm]	h ₁ [mm]	h _{nom} [mm]	h _{ef} [mm]	t _{fix} [mm]	S _{cr,N} [mm]	C _{cr,N} [mm]	S _{cr,sp} [mm]	C _{cr,sp} [mm]	h _{min} [mm]	h ₁ [mm]	h _{nom} [mm]	h _{ef} [mm]	t _{fix} [mm]	S _{cr,N} [mm]	C _{cr,N} [mm]	S _{cr,sp} [mm]	C _{cr,sp} [mm]
TFF	TFF06035	Ø6 x 35 (M8-M10)	X	6	--	SW 13	10	35	35	--	--	--	--	--	--	--	--	--	100	45	35	26,0	--	78	39	90	45
	TFF06055	Ø6 x 55 (M8-M10)	✓			SW 13				100	65	55	43,0	--	129	65	170	85	--	--	--	--	--	--	--	--	--
TFM	TFM06035	Ø6 x 35 (M8)	X	6	--	SW 13	10	35	35	--	--	--	--	--	--	--	--	--	100	65	55	26,0	--	78	39	90	45
	TFM06055	Ø6 x 55 (M10)	✓			SW 13				100	65	55	43,0	--	129	65	170	85	--	--	--	--	--	--	--	--	--
TFS	TFS06100	Ø6 x 100 (M8)	✓	6	9	SW 5	10	35	35	100	65	55	43,0	35	129	65	170	85	100	45	35	26,0	55	78	39	90	45
	TFS06120	Ø6 x 120 (M8)	✓			SW 5								55									75				
	TFS08110	Ø8 x 110 (M10)	✓	8	12	SW 7	20	35	35	100	75	65	50,5	32	152	76	200	100	100	60	50	37,5	47	113	57	130	65
	TFS08130	Ø8 x 130 (M10)	✓			SW 7								52									67				
	TFS10120	Ø10 x 120 (M12)	✓	10	14	SW 8	30	50	40	120	85	75	58,5	27	176	88	190	95	100	65	55	41,5	52	125	63	140	70
	TFS10140	Ø10 x 140 (M12)	✓			SW 8								47									72				

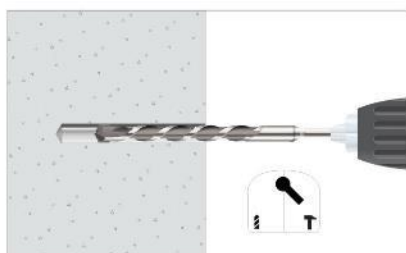
4. PROCESSUS D'INSTALLATION**4.1. INSTALLATION DANS LE BÉTON****1. PERCER**

Vérifier que le béton est bien compact et sans pores significatifs.
Admet des trous secs, humides ou inondés.
Perçage en mode percussion ou marteau.
Percer au diamètre et à la profondeur spécifiée.

**2. SOUFFLER ET NETTOYER**

Nettoyer le trou des restes de poussière et des fragments du perçage.
Utiliser bombe d'air et brosse

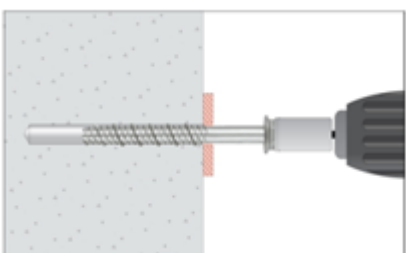
**3. INSTALLER**

Utiliser une clé à choc ou une clé dynamométrique ne dépassant pas les couples de serrage maximaux Timpact,max ou Tins,max respectivement.
Connecter la douille d'installation ou la pointe hexagonal.
Assembler la tête de la vis dans la douille/pointe.

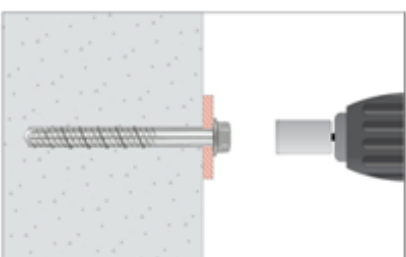
**4. APPLIQUER COUPLE DE SERRAGE**

Insérer la vis dans le trou avec une clé à choc ou une clé dynamométrique à travers la plaque d'ancrage jusqu'à ce que la tête soit en contact avec la plaque. La vis doit rester serrée après l'installation et ne doit plus être desserrée.

5. RÉISTANCES

Les résistances dans le béton C20 / 25 pour un ancrage isolé sans effets de la distance au bord et des distances entre les ancrages sont indiquées dans le tableau suivant :

Les valeurs soulignées et en italique indiquent une défaillance de l'acier, les valeurs en **gras** indiquent une défaillance par le béton et le reste indique une défaillance par extraction.

1 KN ≈ 100 kg

5.1 RESISTANCES CHARACTERISTIQUES (APPLICATION STRUCTURELLE) [kN]

Paramètres généraux				Non-fissuré béton				Fissuré béton				
Familie	Code	Dimension	Evaluation	Traction $N_{Rk, ucr}$		Cisaillemen $V_{Rk, ucr}$		Traction $N_{Rk, ucr}$		Cisaillemen $V_{Rk, ucr}$		
			ETA	($h_{ef, std}$)	($h_{ef, red}$)	($h_{ef, std}$)	($h_{ef, red}$)	($h_{ef, std}$)	($h_{ef, red}$)	($h_{ef, std}$)	($h_{ef, red}$)	
THE	THE05040	Ø5 x 40	--	--	6,88	--	6,88	--	4,91	--	4,91	
	THE05050	Ø5 x 50	--	10,44	6,88	<u><i>8,19</i></u>	6,88	7,45	4,91	7,45	4,91	
	THE05060	Ø5 x 60	--									
	THE05080	Ø5 x 80	--									
	THE05100	Ø5 x 100	--									
	THE06040	Ø6 x 40	✓	--	5,00	--	6,68	--	4,77	--	4,77	
	THE06050	Ø6 x 50	✓	--	14,21	5,00	<u><i>12,53</i></u>	6,68	10,15	4,77	10,15	4,77
	THE06060	Ø6 x 60	✓									
	THE06070	Ø6 x 70	✓									
	THE06080	Ø6 x 80	✓									
	THE06100	Ø6 x 100	✓									
	THE06120	Ø6 x 120	✓									
	THE08055	Ø8 x 55	✓	--	11,57	--	11,57	--	8,27	--	8,27	
	THE08060	Ø8 x 60	✓									
	THE08070	Ø8 x 70	✓									
	THE08080	Ø8 x 80	✓									
	THE08090	Ø8 x 90	✓	18,09	11,57	18,09	11,57	12,92	8,27	12,92	8,27	
	THE08100	Ø8 x 100	✓									
	THE08110	Ø8 x 110	✓									
	THE08120	Ø8 x 120	✓									
	THE08140	Ø8 x 140	✓									
	THE10060	Ø10 x 60	✓									--
	THE10070	Ø10 x 70	✓									
	THE10080	Ø10 x 80	✓									
	THE10090	Ø10 x 90	✓									
	THE10100	Ø10 x 100	✓	27,64	13,47	<u><i>27,40</i></u>	13,47	19,74	9,62	<u><i>27,40</i></u>	9,62	
	THE10120	Ø10 x 120	✓									
	THE10140	Ø10 x 140	✓									
	THE12080	Ø12 x 80	✓									--
	THE12090	Ø12 x 90	✓									
THE12110	Ø12 x 110	✓										
THE12130	Ø12 x 130	✓										
THE12150	Ø12 x 150	✓	38,46	22,26	<u><i>37,24</i></u>	22,26	27,47	15,90	<u><i>37,24</i></u>	15,90		
THE14080	Ø14 x 80	✓										
THE14100	Ø14 x 100	✓										
THE14120	Ø14 x 120	✓										
THE14130	Ø14 x 130	✓	44,47	22,26	<u><i>52,72</i></u>	22,26	31,77	15,90	<u><i>52,72</i></u>	15,90		
THE14140	Ø14 x 140	✓										
THE14160	Ø14 x 160	✓										
THE18100	Ø18 x 100	✓									--	29,20
THE18130	Ø18 x 130	✓										
THE18160	Ø18 x 160	✓										
THE18180	Ø18 x 180	✓										
THE18200	Ø18 x 200	✓	59,74	29,20	<u><i>80,78</i></u>	58,40	42,67	20,86	<u><i>80,78</i></u>	41,72		

Paramètres généraux				Non-fissuré béton				Fissuré béton			
Familie	Code	Dimension	Evaluation	Traction $N_{Rk, ucr}$		Cisaillemen $V_{Rk, ucr}$		Traction $N_{Rk, ucr}$		Cisaillemen $V_{Rk, ucr}$	
			ETA	($h_{ef, std}$)	($h_{ef, red}$)	($h_{ef, std}$)	($h_{ef, red}$)	($h_{ef, std}$)	($h_{ef, red}$)	($h_{ef, std}$)	($h_{ef, red}$)
TFE	TFE05040	Ø5 x 40	--	--	6,88	--	6,88	--	4,91	--	4,91
	TFE05050	Ø5 x 50	--	10,44	6,88	<u>8,19</u>	6,88	7,45	4,91	7,45	4,91
	TFE05060	Ø5 x 60	--								
	TFE05080	Ø5 x 80	--								
	TFE05100	Ø5 x 100	--								
	TFE06040	Ø6 x 40	✓	--	5,00	--	6,68	--	4,77	--	4,77
	TFE06050	Ø6 x 50	✓								
	TFE06060	Ø6 x 60	✓	14,21	5,00	<u>12,53</u>	6,68	10,15	4,77	10,15	4,77
	TFE06070	Ø6 x 70	✓								
	TFE06080	Ø6 x 80	✓								
	TFE06100	Ø6 x 100	✓								
	TFE06120	Ø6 x 120	✓								
	TFE08055	Ø8 x 55	✓								
	TFE08060	Ø8 x 60	✓								
	TFE08070	Ø8 x 70	✓	18,09	11,57	18,09	11,57	12,92	8,27	12,92	8,27
	TFE08080	Ø8 x 80	✓								
	TFE08090	Ø8 x 90	✓								
	TFE08100	Ø8 x 100	✓								
	TFE08110	Ø8 x 110	✓								
	TFE08120	Ø8 x 120	✓								
	TFE08140	Ø8 x 140	✓	--	13,47	--	13,47	--	9,62	--	9,62
	TFE10060	Ø10 x 60	✓								
	TFE10070	Ø10 x 70	✓	--	13,47	--	13,47	--	9,62	--	9,62
	TFE10080	Ø10 x 80	✓								
	TFE10090	Ø10 x 90	✓	27,64	13,47	<u>27,40</u>	13,47	19,74	9,62	<u>27,40</u>	9,62
	TFE10100	Ø10 x 100	✓								
	TFE10120	Ø10 x 120	✓								
	TFE10140	Ø10 x 140	✓								
	TFE12080	Ø12 x 80	✓	--	22,26	--	22,26	--	15,90	--	15,90
	TFE12090	Ø12 x 90	✓								
	TFE12110	Ø12 x 110	✓	38,46	22,26	<u>37,24</u>	22,26	27,47	15,90	<u>37,24</u>	15,90
	TFE12130	Ø12 x 130	✓								
TFE12150	Ø12 x 150	✓									
TFE14080	Ø14 x 80	✓	--	22,26	--	22,26	--	15,90	--	15,90	
TFE14100	Ø14 x 100	✓									
TFE14120	Ø14 x 120	✓	44,47	22,26	<u>52,72</u>	22,26	31,77	15,90	<u>52,72</u>	15,90	
TFE14130	Ø14 x 130	✓									
TFE14140	Ø14 x 140	✓									
TFE14160	Ø14 x 160	✓									
TFE18100	Ø18 x 100	✓	--	29,20	--	58,40	--	20,86	--	41,72	
TFE18130	Ø18 x 130	✓									
TFE18160	Ø18 x 160	✓	59,74	29,20	<u>80,78</u>	58,40	42,67	20,86	<u>80,78</u>	41,72	
TFE18180	Ø18 x 180	✓									
TFE18200	Ø18 x 200	✓									
TFN	TFN14080	Ø14 x 80	✓	--	22,26	--	22,26	--	15,90	--	15,90
THA	THA05040	Ø5 x 40	--	--	6,88	--	6,88	--	4,91	--	4,91
	THA05060	Ø5 x 60	--	10,44	6,88	<u>8,19</u>	6,88	7,45	4,91	7,45	4,91
	THA05080	Ø5 x 80	--								
	THA05100	Ø5 x 100	--								
	THA06045	Ø6 x 45	✓								
	THA06050	Ø6 x 50	✓	--	5,00	--	6,68	--	4,77	--	4,77
	THA06060	Ø6 x 60	✓								
	THA06080	Ø6 x 80	✓	14,21	5,00	<u>12,53</u>	6,68	10,15	4,77	10,15	4,77
	THA06120	Ø6 x 120	✓								
	THA06140	Ø6 x 140	✓								
	THA08060	Ø8 x 60	✓	--	11,57	--	11,57	--	8,27	--	8,27
	THA08080	Ø8 x 80	✓								
	THA08100	Ø8 x 100	✓	18,09	11,57	18,09	11,57	12,92	8,27	12,92	8,27
	THA08120	Ø8 x 120	✓								
	THA10100	Ø10 x 100	✓								
THA10120	Ø10 x 120	✓									

Paramètres généraux				Non-fissuré béton				Fissuré béton			
Familie	Code	Dimension	Evaluation	Traction $N_{Rk, ucr}$		Cisaillemen $V_{Rk, ucr}$		Traction $N_{Rk, ucr}$		Cisaillemen $V_{Rk, ucr}$	
			ETA	($h_{ef, std}$)	($h_{ef, red}$)	($h_{ef, std}$)	($h_{ef, red}$)	($h_{ef, std}$)	($h_{ef, red}$)	($h_{ef, std}$)	($h_{ef, red}$)
THT	THT06040	Ø6 x 40	✓	--	5,00	--	6,68	--	4,77	--	4,77
	THT06050	Ø6 x 50	✓	--		--		--			
	THT06060	Ø6 x 60	✓	14,21	5,00	12,53	6,68	10,15	4,77	10,15	4,77
THP	THP05040	Ø5 x 40	--	--	6,88	--	6,88	--	4,91	--	4,91
	THP05060	Ø5 x 60	--	10,44	6,88	8,19	6,88	7,45	4,91	7,45	4,91
	THP06040	Ø6 x 40	✓	--	5,00	--	6,68	10,15	4,77	--	4,77
	THP06050	Ø6 x 50	✓	--		--		--			
	THP06060	Ø6 x 60	✓	14,21	5,00	12,53	6,68	10,15	4,77	10,15	4,77
	THP06080	Ø6 x 80	✓								
	THP06100	Ø6 x 100	✓								
	THP08060	Ø8 x 60	✓	--	11,57	--	11,57	--	8,27	--	8,27
	THP08080	Ø8 x 80	✓	18,09	11,57	18,09	11,57	12,92	8,27	12,92	8,27
TFF	TFF06035	Ø6 x 35 (M8-M10)	✓	--	5,00	--	--	--	4,77	--	--
	TFF06055	Ø6 x 55 (M8-M10)	✓	14,21	--	--	--	10,15	--	--	--
TFM	TFM06035	Ø6 x 35 (M8)	✓	--	5,00	--	--	--	4,77	--	--
	TFM06055	Ø6 x 55 (M10)	✓	14,21	--	--	--	10,15	--	--	--
TFS	TFS06100	Ø6 x 100 (M8)	✓	14,21	5,00	12,53	6,68	10,15	4,77	10,15	4,77
	TFS06120	Ø6 x 120 (M8)	✓								
	TFS08110	Ø8 x 110 (M10)	✓	18,09	11,57	18,09	11,57	12,92	8,27	12,92	8,27
	TFS08130	Ø8 x 130 (M10)	✓								
	TFS10120	Ø10 x 120 (M12)	✓								
TFS10140	Ø10 x 140 (M12)	✓	22,55	13,47	22,55	13,47	16,11	9,62	16,11	9,62	

5.2 RESISTANCES DE CALCUL (APPLICATION STRUCTURELLE) [kN]

Paramètres généraux			Non-fissuré béton				Fissuré béton				
Familie	Code	Dimension	Evaluation	Traction $N_{Rk, ucr}$		Cisaillemen $V_{Rk, ucr}$		Traction $N_{Rk, ucr}$		Cisaillemen $V_{Rk, ucr}$	
			ETA	($h_{ef, std}$)	($h_{ef, red}$)	($h_{ef, std}$)	($h_{ef, red}$)	($h_{ef, std}$)	($h_{ef, red}$)	($h_{ef, std}$)	($h_{ef, red}$)
THE	THE05040	Ø5 x 40	--	--	4,58	--	4,58	--	3,27	--	3,27
	THE05050	Ø5 x 50	--								
	THE05060	Ø5 x 60	--								
	THE05080	Ø5 x 80	--	6,96	4,58	<u>5,46</u>	4,58	4,97	3,27	4,97	3,27
	THE05100	Ø5 x 100	--								
	THE06040	Ø6 x 40	✓	--							
	THE06050	Ø6 x 50	✓	--	2,78	--	4,45	--	2,65	--	3,18
	THE06060	Ø6 x 60	✓								
	THE06070	Ø6 x 70	✓								
	THE06080	Ø6 x 80	✓	9,47	2,78	<u>8,35</u>	4,45	6,77	2,65	6,77	3,18
	THE06100	Ø6 x 100	✓								
	THE06120	Ø6 x 120	✓								
	THE08055	Ø8 x 55	✓	--							
	THE08060	Ø8 x 60	✓	--	6,43	--	7,72	--	4,59	--	5,51
	THE08070	Ø8 x 70	✓								
	THE08080	Ø8 x 80	✓								
	THE08090	Ø8 x 90	✓								
	THE08100	Ø8 x 100	✓	12,06	6,43	12,06	7,72	8,61	4,59	8,61	5,51
	THE08110	Ø8 x 110	✓								
	THE08120	Ø8 x 120	✓								
	THE08140	Ø8 x 140	✓								
	THE10060	Ø10 x 60	✓	--							
	THE10070	Ø10 x 70	✓	--	8,98	--	8,98	--	6,42	--	6,42
	THE10080	Ø10 x 80	✓	--							
	THE10090	Ø10 x 90	✓								
	THE10100	Ø10 x 100	✓								
	THE10120	Ø10 x 120	✓	18,43	8,98	<u>18,27</u>	8,98	13,16	6,42	<u>18,27</u>	6,42
	THE10140	Ø10 x 140	✓								
	THE12080	Ø12 x 80	✓	--	14,84	--	14,84	--	10,60	--	10,60
	THE12090	Ø12 x 90	✓	--							
THE12110	Ø12 x 110	✓									
THE12130	Ø12 x 130	✓	25,64	14,84	<u>24,83</u>	14,84	18,31	10,60	<u>24,83</u>	10,60	
THE12150	Ø12 x 150	✓									
THE14080	Ø14 x 80	✓	--	14,84	--	14,84	--	10,60	--	10,60	
THE14100	Ø14 x 100	✓	--								
THE14120	Ø14 x 120	✓									
THE14130	Ø14 x 130	✓	29,65	14,84	<u>35,15</u>	14,84	21,18	10,60	<u>35,15</u>	10,60	
THE14140	Ø14 x 140	✓									
THE14160	Ø14 x 160	✓									
THE18100	Ø18 x 100	✓	--	19,47	--	38,94	--	13,91	--	27,81	
THE18130	Ø18 x 130	✓	--								
THE18160	Ø18 x 160	✓									
THE18180	Ø18 x 180	✓	39,83	19,47	<u>53,85</u>	38,94	28,45	13,91	<u>53,85</u>	27,81	
THE18200	Ø18 x 200	✓									

Paramètres généraux				Non-fissuré béton				Fissuré béton											
Familie	Code	Dimension	Evaluation	Traction $N_{Rk, ucr}$		Cisaillemen $V_{Rk, ucr}$		Traction $N_{Rk, ucr}$		Cisaillemen $V_{Rk, ucr}$									
			ETA	($h_{ef, std}$)	($h_{ef, red}$)	($h_{ef, std}$)	($h_{ef, red}$)	($h_{ef, std}$)	($h_{ef, red}$)	($h_{ef, std}$)	($h_{ef, red}$)								
TFE	TFE05040	Ø5 x 40	--	--	4,58	--	4,58	--	3,27	--	3,27								
	TFE05050	Ø5 x 50	--	6,96	4,58	5,46	4,58	4,97	3,27	4,97	3,27								
	TFE05060	Ø5 x 60	--																
	TFE05080	Ø5 x 80	--																
	TFE05100	Ø5 x 100	--																
	TFE06040	Ø6 x 40	✓	--	2,78	--	4,45	--	2,65	--	3,18								
	TFE06050	Ø6 x 50	✓																
	TFE06060	Ø6 x 60	✓	9,47	2,78	8,35	4,45	6,77	2,65	6,77	3,18								
	TFE06070	Ø6 x 70	✓																
	TFE06080	Ø6 x 80	✓																
	TFE06100	Ø6 x 100	✓																
	TFE06120	Ø6 x 120	✓																
	TFE08055	Ø8 x 55	✓									--	6,43	--	7,72	--	4,59	--	5,51
	TFE08060	Ø8 x 60	✓																
	TFE08070	Ø8 x 70	✓	12,06	6,43	12,06	7,72	8,61	4,59	8,61	5,51								
	TFE08080	Ø8 x 80	✓																
	TFE08090	Ø8 x 90	✓																
	TFE08100	Ø8 x 100	✓																
	TFE08110	Ø8 x 110	✓																
	TFE08120	Ø8 x 120	✓																
	TFE08140	Ø8 x 140	✓																
	TFE10060	Ø10 x 60	✓	--	8,98	--	8,98	--	6,42	--	6,42								
	TFE10070	Ø10 x 70	✓																
	TFE10080	Ø10 x 80	✓	--	18,43	8,98	18,27	8,98	13,16	6,42	18,27	6,42							
	TFE10090	Ø10 x 90	✓																
	TFE10100	Ø10 x 100	✓																
	TFE10120	Ø10 x 120	✓																
	TFE10140	Ø10 x 140	✓																
	TFE12080	Ø12 x 80	✓	--									14,84	--	14,84	--	10,60	--	10,60
	TFE12090	Ø12 x 90	✓																
	TFE12110	Ø12 x 110	✓	25,64	14,84	24,83	14,84	18,31	10,60	24,83	10,60								
	TFE12130	Ø12 x 130	✓																
TFE12150	Ø12 x 150	✓																	
TFE14080	Ø14 x 80	✓	--									14,84	--	14,84	--	10,60	--	10,60	
TFE14100	Ø14 x 100	✓																	
TFE14120	Ø14 x 120	✓	29,65	14,84	35,15	14,84	21,18	10,60	35,15	10,60									
TFE14130	Ø14 x 130	✓																	
TFE14140	Ø14 x 140	✓																	
TFE14160	Ø14 x 160	✓																	
TFE18100	Ø18 x 100	✓	--	19,47	--	38,94	--	13,91	--	27,81									
TFE18130	Ø18 x 130	✓																	
TFE18160	Ø18 x 160	✓	39,83	19,47	53,85	38,94	28,45	13,91	53,85	27,81									
TFE18180	Ø18 x 180	✓																	
TFE18200	Ø18 x 200	✓																	
TFN14080	Ø14 x 80	✓									--	14,84	--	14,84	--	10,60	--	10,60	
THA	THA05040	Ø5 x 40	--	--	4,58	--	4,58	--	3,27	--	3,27								
	THA05060	Ø5 x 60	--	6,96	4,58	5,46	4,58	4,97	3,27	4,97	3,27								
	THA05080	Ø5 x 80	--																
	THA05100	Ø5 x 100	--																
	THA06045	Ø6 x 45	✓									--	2,78	--	4,45	--	2,65	--	3,18
	THA06050	Ø6 x 50	✓																
	THA06060	Ø6 x 60	✓	9,47	2,78	8,35	4,45	6,77	2,65	6,77	3,18								
	THA06080	Ø6 x 80	✓																
	THA06120	Ø6 x 120	✓																
	THA06140	Ø6 x 140	✓																
	THA08060	Ø8 x 60	✓									--	6,43	--	7,72	--	4,59	--	5,51
	THA08080	Ø8 x 80	✓																
	THA08100	Ø8 x 100	✓	12,06	6,43	12,06	7,72	8,61	4,59	8,61	5,51								
	THA08120	Ø8 x 120	✓																
	THA10100	Ø10 x 100	✓									18,43	8,98	18,27	8,98	13,16	6,42	18,27	6,42
	THA10120	Ø10 x 120	✓																

Paramètres généraux				Non-fissuré béton				Fissuré béton			
Familie	Code	Dimension	Evaluation	Traction N _{Rk, ucr}		Cisaillemen V _{Rk, ucr}		Traction N _{Rk, ucr}		Cisaillemen V _{Rk, ucr}	
			ETA								
THT	THT06040	Ø6 x 40	✓	--	2,78	--	4,45	--	2,65	--	3,18
	THT06050	Ø6 x 50	✓	--		--		--		--	
	THT06060	Ø6 x 60	✓	9,47	2,78	<u>8,35</u>	4,45	6,77	2,65	6,77	3,18
THP	THP05040	Ø5 x 40	--	--	4,58	--	4,58	--	3,27	--	3,27
	THP05060	Ø5 x 60	--	6,96	4,58	<u>5,46</u>	4,58	4,97	3,27	4,97	3,27
	THP06040	Ø6 x 40	✓	--		--		--		--	
	THP06050	Ø6 x 50	✓	--	2,78	--	4,45	--	2,65	--	3,18
	THP06060	Ø6 x 60	✓								
	THP06080	Ø6 x 80	✓	9,47	2,78	<u>8,35</u>	4,45	6,77	2,65	6,77	3,18
	THP06100	Ø6 x 100	✓								
	THP08060	Ø8 x 60	✓	--	6,43	--	7,72	--	4,59	--	5,51
	THP08080	Ø8 x 80	✓	12,06	6,43	12,06	7,72	8,61	4,59	8,61	5,51
TFF	TFF06035	Ø6 x 35 (M8-M10)	✓	--	2,78	--	--	--	2,65	--	--
	TFF06055	Ø6 x 55 (M8-M10)	✓	9,47	--	--	--	6,77	--	--	--
TFM	TFM06035	Ø6 x 35 (M8)	✓	--	2,78	--	--	--	2,65	--	--
	TFM06055	Ø6 x 55 (M10)	✓	9,47	--	--	--	6,77	--	--	--
TFS	TFS06100	Ø6 x 100 (M8)	✓								
	TFS06120	Ø6 x 120 (M8)	✓	9,47	2,78	<u>8,35</u>	4,45	6,77	2,65	6,77	3,18
	TFS08110	Ø8 x 110 (M10)	✓								
	TFS08130	Ø8 x 130 (M10)	✓	12,06	6,43	12,06	7,72	8,61	4,59	8,61	5,51
	TFS10120	Ø10 x 120 (M12)	✓								
TFS10140	Ø10 x 140 (M12)	✓	15,03	8,98	15,03	8,98	10,74	6,42	10,74	6,42	

5.3 CHARGES MAXIMALES RECOMMANDÉES (APPLICATION STRUCTURELLE) [kN] (avec $\gamma_F= 1.4$)

Paramètres généraux			Non-fissuré béton				Fissuré béton				
Familie	Code	Dimension	Evaluation	Traction $N_{Rk, ucr}$		Cisaillemen $V_{Rk, ucr}$		Traction $N_{Rk, ucr}$		Cisaillemen $V_{Rk, ucr}$	
			ETA	($h_{ef, std}$)	($h_{ef, red}$)	($h_{ef, std}$)	($h_{ef, red}$)	($h_{ef, std}$)	($h_{ef, red}$)	($h_{ef, std}$)	($h_{ef, red}$)
THE	THE05040	Ø5 x 40	--	--	3,27	--	3,27	--	2,34	--	2,34
	THE05050	Ø5 x 50	--								
	THE05060	Ø5 x 60	--	4,97	3,27	<u>3,90</u>	3,27	3,55	2,34	3,55	2,34
	THE05080	Ø5 x 80	--								
	THE05100	Ø5 x 100	--								
	THE06040	Ø6 x 40	✓	--	1,98	--	3,18	--	1,89	--	2,27
	THE06050	Ø6 x 50	✓								
	THE06060	Ø6 x 60	✓	6,77	1,98	<u>5,97</u>	3,18	4,83	1,89	4,83	2,27
	THE06070	Ø6 x 70	✓								
	THE06080	Ø6 x 80	✓								
	THE06100	Ø6 x 100	✓								
	THE06120	Ø6 x 120	✓								
	THE08055	Ø8 x 55	✓	--	4,59	--	5,51	--	3,28	--	3,94
	THE08060	Ø8 x 60	✓								
	THE08070	Ø8 x 70	✓	8,61	4,59	8,61	5,51	6,15	3,28	6,15	3,94
	THE08080	Ø8 x 80	✓								
	THE08090	Ø8 x 90	✓								
	THE08100	Ø8 x 100	✓								
	THE08110	Ø8 x 110	✓								
	THE08120	Ø8 x 120	✓								
	THE08140	Ø8 x 140	✓	--	6,42	--	6,42	--	4,58	--	4,58
	THE10060	Ø10 x 60	✓								
	THE10070	Ø10 x 70	✓	--	6,42	--	6,42	--	4,58	--	4,58
	THE10080	Ø10 x 80	✓								
	THE10090	Ø10 x 90	✓	13,16	6,42	<u>13,05</u>	6,42	9,40	4,58	<u>13,05</u>	4,58
	THE10100	Ø10 x 100	✓								
	THE10120	Ø10 x 120	✓								
	THE10140	Ø10 x 140	✓								
	THE12080	Ø12 x 80	✓	--	10,60	--	10,60	--	7,57	--	7,57
	THE12090	Ø12 x 90	✓								
	THE12110	Ø12 x 110	✓	18,31	10,60	<u>17,73</u>	10,60	13,08	7,57	<u>17,73</u>	7,57
	THE12130	Ø12 x 130	✓								
THE12150	Ø12 x 150	✓									
THE14080	Ø14 x 80	✓	--	10,60	--	10,60	--	7,57	--	7,57	
THE14100	Ø14 x 100	✓									
THE14120	Ø14 x 120	✓	21,18	10,60	<u>25,10</u>	10,60	15,13	7,57	<u>25,10</u>	7,57	
THE14130	Ø14 x 130	✓									
THE14140	Ø14 x 140	✓									
THE14160	Ø14 x 160	✓									
THE18100	Ø18 x 100	✓	--	13,91	--	27,81	--	9,93	--	19,87	
THE18130	Ø18 x 130	✓									
THE18160	Ø18 x 160	✓	28,45	13,91	<u>38,47</u>	27,81	20,32	9,93	<u>38,47</u>	19,87	
THE18180	Ø18 x 180	✓									
THE18200	Ø18 x 200	✓									

Paramètres généraux				Non-fissuré béton				Fissuré béton											
Familie	Code	Dimension	Evaluation	Traction $N_{Rk, ucr}$		Cisaillemen $V_{Rk, ucr}$		Traction $N_{Rk, ucr}$		Cisaillemen $V_{Rk, ucr}$									
			ETA	($h_{ef, std}$)	($h_{ef, red}$)	($h_{ef, std}$)	($h_{ef, red}$)	($h_{ef, std}$)	($h_{ef, red}$)	($h_{ef, std}$)	($h_{ef, red}$)								
TFE	TFE05040	Ø5 x 40	--	--	3,27	--	3,27	--	2,34	--	2,34								
	TFE05050	Ø5 x 50	--	4,97	3,27	<u>3,90</u>	3,27	3,55	2,34	3,55	2,34								
	TFE05060	Ø5 x 60	--																
	TFE05080	Ø5 x 80	--																
	TFE05100	Ø5 x 100	--																
	TFE06040	Ø6 x 40	✓	--	1,98	--	3,18	--	1,89	--	2,27								
	TFE06050	Ø6 x 50	✓																
	TFE06060	Ø6 x 60	✓	6,77	1,98	<u>5,97</u>	3,18	4,83	1,89	4,83	2,27								
	TFE06070	Ø6 x 70	✓																
	TFE06080	Ø6 x 80	✓																
	TFE06100	Ø6 x 100	✓																
	TFE06120	Ø6 x 120	✓																
	TFE08055	Ø8 x 55	✓									--	4,59	--	5,51	--	3,28	--	3,94
	TFE08060	Ø8 x 60	✓																
	TFE08070	Ø8 x 70	✓	8,61	4,59	8,61	5,51	6,15	3,28	6,15	3,94								
	TFE08080	Ø8 x 80	✓																
	TFE08090	Ø8 x 90	✓																
	TFE08100	Ø8 x 100	✓																
	TFE08110	Ø8 x 110	✓																
	TFE08120	Ø8 x 120	✓																
	TFE08140	Ø8 x 140	✓	--	6,42	--	6,42	--	4,58	--	4,58								
	TFE10060	Ø10 x 60	✓																
	TFE10070	Ø10 x 70	✓	--	6,42	--	6,42	--	4,58	--	4,58								
	TFE10080	Ø10 x 80	✓																
	TFE10090	Ø10 x 90	✓	13,16	6,42	<u>13,05</u>	6,42	9,40	4,58	<u>13,05</u>	4,58								
	TFE10100	Ø10 x 100	✓																
	TFE10120	Ø10 x 120	✓																
	TFE10140	Ø10 x 140	✓																
	TFE12080	Ø12 x 80	✓	--	10,60	--	10,60	--	7,57	--	7,57								
	TFE12090	Ø12 x 90	✓																
	TFE12110	Ø12 x 110	✓	18,31	10,60	<u>17,73</u>	10,60	13,08	7,57	<u>17,73</u>	7,57								
	TFE12130	Ø12 x 130	✓																
TFE12150	Ø12 x 150	✓																	
TFE14080	Ø14 x 80	✓	--									10,60	--	10,60	--	7,57	--	7,57	
TFE14100	Ø14 x 100	✓																	
TFE14120	Ø14 x 120	✓	21,18	10,60	<u>25,10</u>	10,60	15,13	7,57	<u>25,10</u>	7,57									
TFE14130	Ø14 x 130	✓																	
TFE14140	Ø14 x 140	✓																	
TFE14160	Ø14 x 160	✓																	
TFE18100	Ø18 x 100	✓	--	13,91	--	27,81	--	9,93	--	19,87									
TFE18130	Ø18 x 130	✓																	
TFE18160	Ø18 x 160	✓	28,45	13,91	<u>38,47</u>	27,81	20,32	9,93	<u>38,47</u>	19,87									
TFE18180	Ø18 x 180	✓																	
TFE18200	Ø18 x 200	✓																	
TFN	TFN14080	Ø14 x 80									✓	--	10,60	--	10,60	--	7,57	--	7,57
THA	THA05040	Ø5 x 40	--	--	3,27	--	3,27	--	2,34	--	2,34								
	THA05060	Ø5 x 60	--	4,97	3,27	<u>3,90</u>	3,27	3,55	2,34	3,55	2,34								
	THA05080	Ø5 x 80	--																
	THA05100	Ø5 x 100	--																
	THA06045	Ø6 x 45	✓																
	THA06050	Ø6 x 50	✓	--	1,98	--	3,18	--	1,89	--	2,27								
	THA06060	Ø6 x 60	✓																
	THA06080	Ø6 x 80	✓	6,77	1,98	<u>5,97</u>	3,18	4,83	1,89	4,83	2,27								
	THA06120	Ø6 x 120	✓																
	THA06140	Ø6 x 140	✓																
	THA08060	Ø8 x 60	✓									--	4,59	--	5,51	--	3,28	--	3,94
	THA08080	Ø8 x 80	✓																
	THA08100	Ø8 x 100	✓									8,61	4,59	8,61	5,51	6,15	3,28	6,15	3,94
	THA08120	Ø8 x 120	✓																
	THA10100	Ø10 x 100	✓	13,16	6,42	<u>13,05</u>	6,42	9,40	4,58	<u>13,05</u>	4,58								
	THA10120	Ø10 x 120	✓																

Paramètres généraux				Non-fissuré béton				Fissuré béton			
Familie	Code	Dimension	Evaluation	Traction $N_{Rk, ucr}$		Cisaillemen $V_{Rk, ucr}$		Traction $N_{Rk, ucr}$		Cisaillemen $V_{Rk, ucr}$	
			ETA	($h_{ef, std}$)	($h_{ef, red}$)	($h_{ef, std}$)	($h_{ef, red}$)	($h_{ef, std}$)	($h_{ef, red}$)	($h_{ef, std}$)	($h_{ef, red}$)
THT	THT06040	Ø6 x 40	✓	--	1,98	--	3,18	--	1,89	--	2,27
	THT06050	Ø6 x 50	✓	--	1,98	--	3,18	--	1,89	--	2,27
	THT06060	Ø6 x 60	✓	6,77	1,98	5,97	3,18	4,83	1,89	4,83	2,27
THP	THP05040	Ø5 x 40	--	--	3,27	--	3,27	--	2,34	--	2,34
	THP05060	Ø5 x 60	--	4,97	3,27	3,90	3,27	3,55	2,34	3,55	2,34
	THP06040	Ø6 x 40	✓	--	1,98	--	3,18	--	1,89	--	2,27
	THP06050	Ø6 x 50	✓	--	1,98	--	3,18	--	1,89	--	2,27
	THP06060	Ø6 x 60	✓	--	1,98	--	3,18	--	1,89	--	2,27
	THP06080	Ø6 x 80	✓	6,77	1,98	5,97	3,18	4,83	1,89	4,83	2,27
	THP06100	Ø6 x 100	✓	--	1,98	--	3,18	--	1,89	--	2,27
	THP08060	Ø8 x 60	✓	--	4,59	--	5,51	--	3,28	--	3,94
	THP08080	Ø8 x 80	✓	8,61	4,59	8,61	5,51	6,15	3,28	6,15	3,94
TFF	TFF06035	Ø6 x 35 (M8-M10)	✓	--	1,98	--	--	--	1,89	--	--
	TFF06055	Ø6 x 55 (M8-M10)	✓	6,77	--	--	--	4,83	--	--	--
TFM	TFM06035	Ø6 x 35 (M8)	✓	--	1,98	--	--	--	1,89	--	--
	TFM06055	Ø6 x 55 (M10)	✓	6,77	--	--	--	4,83	--	--	--
TFS	TFS06100	Ø6 x 100 (M8)	✓	6,77	1,98	5,97	3,18	4,83	1,89	4,83	2,27
	TFS06120	Ø6 x 120 (M8)	✓	--	1,98	--	3,18	--	1,89	--	2,27
	TFS08110	Ø8 x 110 (M10)	✓	8,61	4,59	8,61	5,51	6,15	3,28	6,15	3,94
	TFS08130	Ø8 x 130 (M10)	✓	--	4,59	--	5,51	--	3,28	--	3,94
	TFS10120	Ø10 x 120 (M12)	✓	10,74	6,42	10,74	6,42	7,67	4,58	7,67	4,58

COEFFICIENT DE MAJORATION A EXTRACTION POUR CHARGUES A TRACTION DANS DU BÉTON HAUTE RÉSIDENCE ψ_c															
Diamètre	Ø5		Ø6		Ø8		Ø10			Ø12		Ø14		Ø18	
Profondeur d'installation	($h_{ef, red}$)	($h_{ef, std}$)	($h_{ef, red}$)	($h_{ef, std}$)	($h_{ef, red}$)	($h_{ef, std}$)	($h_{ef, 1}$)	($h_{ef, 2}$)	($h_{ef, 3}$)	($h_{ef, red}$)	($h_{ef, std}$)	($h_{ef, red}$)	($h_{ef, std}$)	($h_{ef, red}$)	($h_{ef, std}$)
C30/37	1,00	1,00	1,16	1,22	1,21	1,22	1,22	1,17	1,22	1,16	1,22	1,21	1,20	1,22	1,17
C40/50	1,00	1,00	1,28	1,41	1,39	1,41	1,41	1,30	1,41	1,29	1,41	1,39	1,37	1,40	1,32
C50/60	1,00	1,00	1,39	1,58	1,54	1,58	1,58	1,42	1,58	1,40	1,58	1,55	1,51	1,57	1,42

6. DOCUMENTATION OFFICIELLE

Par l'intermédiaire de notre service commercial ou de notre site web www.indexfix.com, vous pouvez obtenir les documents suivants :

- Evaluation européen ETA 20/0046 pour l'installation dans du béton non fissuré selon le guide EAD 330232-00-0601, option 1, de Ø6 à Ø18.
- Certificat AVCP 1219-CPR-0254 pour utilisation dans le béton.
- Déclaration of performance DoP THE.
- Disponible pour le programme de calcul des ancrés INDEXcal.